



Open circuit cooling towers

for small-medium installations

TORRAVAL
cooling



PMS K19 SERIES COOLING TOWER

The PMS K19 series cooling tower are built entirely in fibre-glass (orthophthalic polyester resin, reinforced with several layers of glass fibre matting) in order to avoid corrosion problems due to the fact that the tower is constantly in contact with water and it is exposed to all kinds of weather. The structure is self-supporting and strengthened at the points of greatest dynamic and static stress. Moreover, the fibreglass surface is protected by a gelcoat that is resistant to UV rays, hot and cold water and abrasion due to weather and chemicals.

The basin has a sloping bottom with rounded off corners, to enable an easy emptying to simplify its cleaning.

The filling material is made of self-extinguishing PVC with 19 mm flute.

The multi-blade axial fan (with blades in plastic material reinforced with glass fibre) grants high performances with low electrical power input and low noise levels.

The PMS K19 series includes 7 models, all available with or without water basin, for a range of cooling capacities from approx. 50 kW to 700 kW (indicative values referred to nominal temperatures conditions 40°C in, 30°C out, 24°C wet bulb).



ACCESSORIES AND CONSTRUCTION VARIANTS

The following accessories and/or construction variants are available for all models on request:

- Three-phase heating element with control thermostat.
- Minimum level cut-out switch.
- Control panel.
- Manholes / removable side-walls to allow inspection, easy cleaning and maintenance to the internal components of the cooling tower.



THE PMS K19 SERIES IS ALSO AVAILABLE IN OTHER VERSIONS

- **CW**, for clean water.
- **NVP**, for water containing moderate quantities of suspended solids.
- **GS**, for water containing high quantities of suspended solids.
- **ATT**, for high temperature water.
- **PMS K12**, Eurovent/CTI certification.

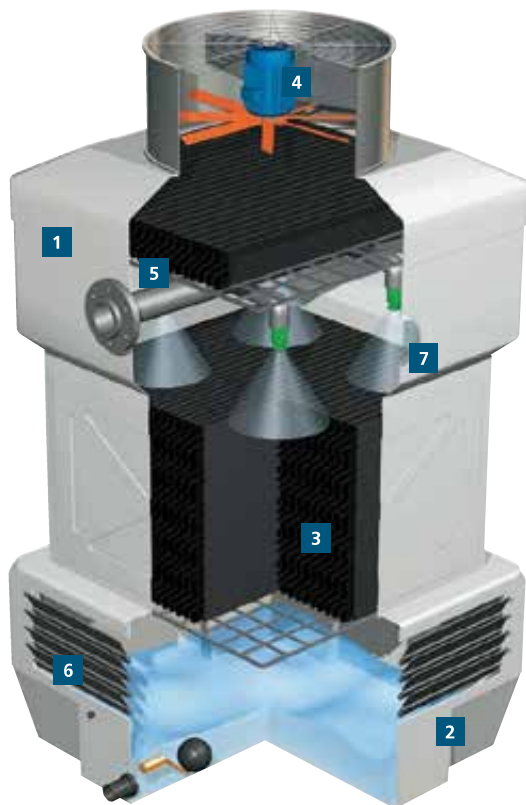

1 Main casing and top cap

Material:

Orthophthalic polyester resin, reinforced with several layers of glass fibre matting.

Characteristics:

- Self supporting structure strengthened at the points of greatest dynamic and static stress.
- External surface protection with gel-coating resistant to uv rays, cold and hot water, abrasion due to weather and chemicals.
- Light-weight.
- Non corroding.

2 Water basin (optional)

Material:

Orthophthalic polyester resin, reinforced with several layers of glass fibre matting.

Characteristics:

- External surface protection with gel-coating resistant to uv rays, cold and hot water, abrasion due to weather and chemicals.
- Internal waterproof protection thanks to an impermeable, water repellent, paraffin containing orthophthalic gelcoat.
- Sloping bottom with rounded off corners, to enable an easy emptying to simplify its cleaning
- Light-weight.
- Non corroding.

3 Filling material (or heat exchange surface)

Material:

Self-extinguishing PVC.

Characteristics:

- 19 mm flute (air/water passage).
- Reinforced top layer to better absorb dynamic stress caused by the under pressure sprayed water from the nozzles.

4 Multi-blade axial fan

Material:

Motor support: hot dip galvanized steel (after all works), fan blades: plastic material, fan screening grid: stainless steel.

Characteristics:

- High performance, low electrical power input, low noise levels.
- Directly coupled to the electric motor.
- Unalterable safety over time thanks to the fan screening grid.
- Non-corroding.

5 Hot water distribution system

Material:

PN 10 unified PVC, PP, PE pipes, polypropylene nozzles.

Characteristics:

- Non-corroding.
- Uniform and total spraying of the heat exchange filling pack.

CONSTRUCTION DETAILS

- Torralval exclusive nozzles design, with non-clogging wide passages for a full cone spray.

6 Anti-splash louvers on air intake openings

Material:

Fibreglass louver (on request: PP panels in a suitable galvanized steel frame).

Characteristics:

- Non corroding.
- Easy to remove even after many years of use.

7 Visual inspection window

Material:

Nylon reinforced with glass fibre.

8 Bolts, nuts and washers

Material:

Stainless steel 304.

Characteristics:

- Non corroding.
- Easy to remove even after many years of use.

PMS K19 Series with water basin

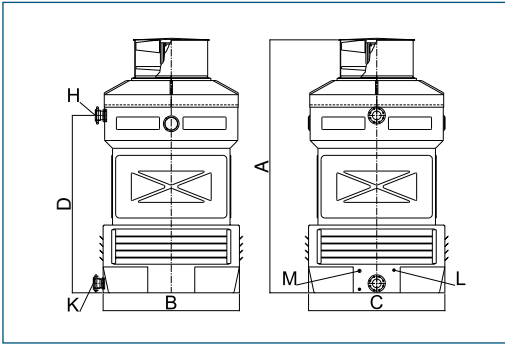

PMS K19 Series without water basin

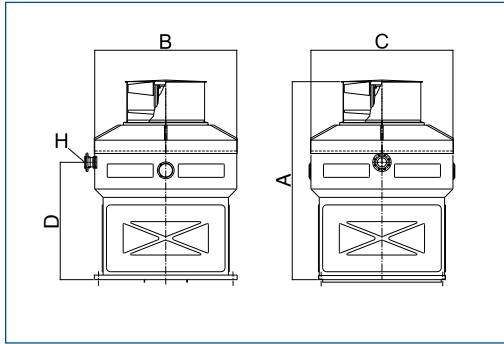

DIMENSIONS AND WEIGHTS

Model	Dimensions				Water connections				Total nameplate fan motor power kW	Weights	
	A	B	C	D	H	K	L	M		empty	in operation
	mm	mm	mm	mm	Ø in	Ø in	Ø in	Ø in		kg	kg
with water basin											
PMS 6/65 K19	2190	800	800	1500	2"	2"	¾"	½"	0,55	75	180
PMS 9/85 K19	2695	1000	1000	1900	2 ½"	2 ½"	¾"	½"	0,75	95	285
PMS 9/110 K19	2870	1200	1200	2000	3"	3"	1"	¾"	1,1	170	485
PMS 9/130 K19	2935	1400	1400	1900	4"	4"	1"	¾"	1,5	210	780
PMS 10/180 K19	3200	1740	1740	2060	4"	4"	1 ¼"	1"	2,2	410	1410
PMS 10/240 K19	3515	2100	1900	2240	4"	5"	1 ¼"	1"	4	525	1825
PMS 10/260 K19	3530	2300	2100	2250	5"	6"	1 ½"	1 ¼"	4	580	1980
without water basin											
PMS 6/65 K19	1670	770	770	990	2"	-	-	-	0,55	60	80
PMS 9/85 K19	2025	980	980	1230	2 ½"	-	-	-	0,75	75	100
PMS 9/110 K19	2240	1215	1215	1385	3"	-	-	-	1,1	135	185
PMS 9/130 K19	2270	1370	1370	1270	4"	-	-	-	1,5	165	225
PMS 10/180 K19	2335	1715	1715	1230	4"	-	-	-	2,2	325	440
PMS 10/240 K19	2485	1805	2050	1235	4"	-	-	-	4	430	535
PMS 10/260 K19	2550	2010	2210	1270	5"	-	-	-	4	490	600

Technical data not binding

For data concerning other versions, please write to: info@torraval.com.



Avda. Autonomía, 4-1ª Planta - Edificio Vega de Lamiako - 48940 LEIOA (Vizcaya), Spain

Tel. +34 94 452 00 00 - Fax +34 94 452 00 50 - info@torraval.com - www.torraval.com